

GEIST



Corporate Office: 1821 Yolande Ave., Lincoln, NE 68521
800.432.3219 + 402.474.3400
www.geistmfg.com

UK Office: Unit 1, The Monarch Centre, Venture Way,
Priorswood, Tauton, Somerset, UK, TA2 8DE
+44 (0) 1823 425 350

GEIST

Please note the information contained herein is intended for informational purposes only. Since products described above may require certain operating conditions this document should not be interpreted to be a commitment on the part of Geist. Also because Geist must respond to changing market conditions, the specifications are subject to change without notice. Geist makes no warranties, expressed or implied, on the information contained in this document.

Power. Cool. Monitor. Manage.

Geist gives you the power to integrate all aspects of your data center infrastructure.

Maximize IT density and lower operating costs with Geist intelligent cooling solutions.

Why **GEIST**

Our superior service and integrated solutions enable you to build the next generation of data centers.

Our Vision: Geist will be seen by our clients as the best company they have ever dealt with; not just compared to our competitors, but as compared to all of the companies the client deals with.

COST-EFFECTIVE CUSTOMIZATION

products built to order
unmatched lead times

IN-HOUSE EXPERTISE

on-site UL® / CE® accredited testing lab
made in the USA

QUALITY BUILT-IN

all units 100% tested on site
ISO 9001:2008

RAPID ORDER FULFILLMENT

orders ship within 3-5 days
record of 99.5% on-time delivery

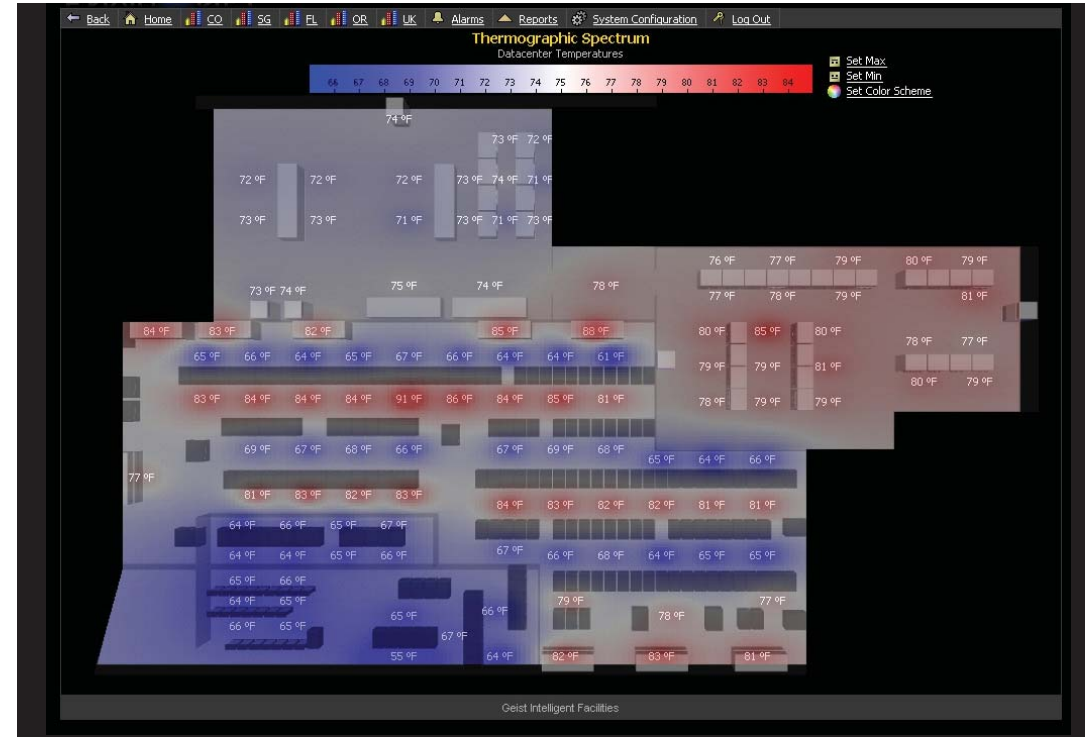

geist SOLUTIONS

COOL

- Normalize Server Intake: containment of server exhaust can eliminate thermal mixing and hot spots
- Maximum Cooling Efficiency: heat separation delivers highest return temperatures to CRAC/CRAH units
- Improved Fan Efficiency: server air consumption matches system supply, eliminating air oversupply
- Scale to Load: add system capacity as required to match growing load demand
- Intelligent Control: control cooling requirements at the cabinet level, while relying on traditional cooling methods, and keep water off your data center floor

MONITOR

- Fully Integrated Solution: full suite of Environmental Monitoring products which integrate Power Distribution Units or Environmental Monitoring units
- Streamline Operations: broad range of sensors covering temperature, humidity, airflow, dew point, DC battery status, door position, water and smoke detection
- Intuitive User Interface: on-board web server provides a flexible interface for reporting and notification

industry LEADER

- Established in 1948, 63 years of continuous growth
- Privately held company, division of PCE, Inc.
- 14 office locations in US, China and Europe
- Manufacturing facilities in US and UK
- Installations globally
- Partnerships in the UK, China, Taiwan, France, Australia and South Africa



Customer Service
Monday-Friday 7:30AM-6:00PM (CST)

Geist Manufacturing
1821 Yolande Ave., Lincoln, NE 68521
800.432.3219 | 402.474.3400 | +44 (0) 1823 425 350 (UK)
www.geistmfg.com | products@geistmfg.com

MANAGE

- Multi-application Support: comprehensive management system monitoring and controlling ALL aspects of the Data Center infrastructure
- Versatile Platform: combine data from switchgear, RPPs, PDUs, generators, chillers, CRACs and environmental devices for energy usage analysis, PUE and DCIE
- Easy to Deploy - vendor neutral protocols - SNMP, Modbus (485/232/IP), BACnet, LonWorks, OPC, Legacy (Veeder Root)
- Scalable - suitable for any facility size, large or small
- Optimized - designed for your data center with fully interactive meaningful views and custom reports



Geist cabinet based heat containment is the new evolution in containment cooling methodology.

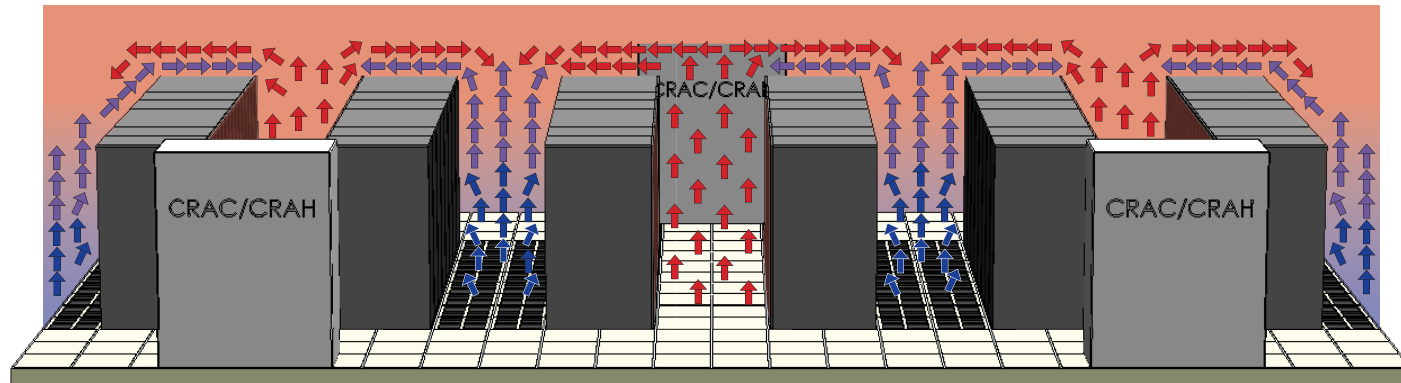

traditional **HOT AISLE/COLD AISLE** deployment

- Substantial mixing of hot and cold air leads to hot spots
- Mixed air leads to low CRAC/CRAH return temperatures, decreasing cooling efficiency
- Floor tile “gymnastics” are required to attempt to handle or eliminate hot spots
- Environment must be micromanaged as adds, moves and changes move heat loads

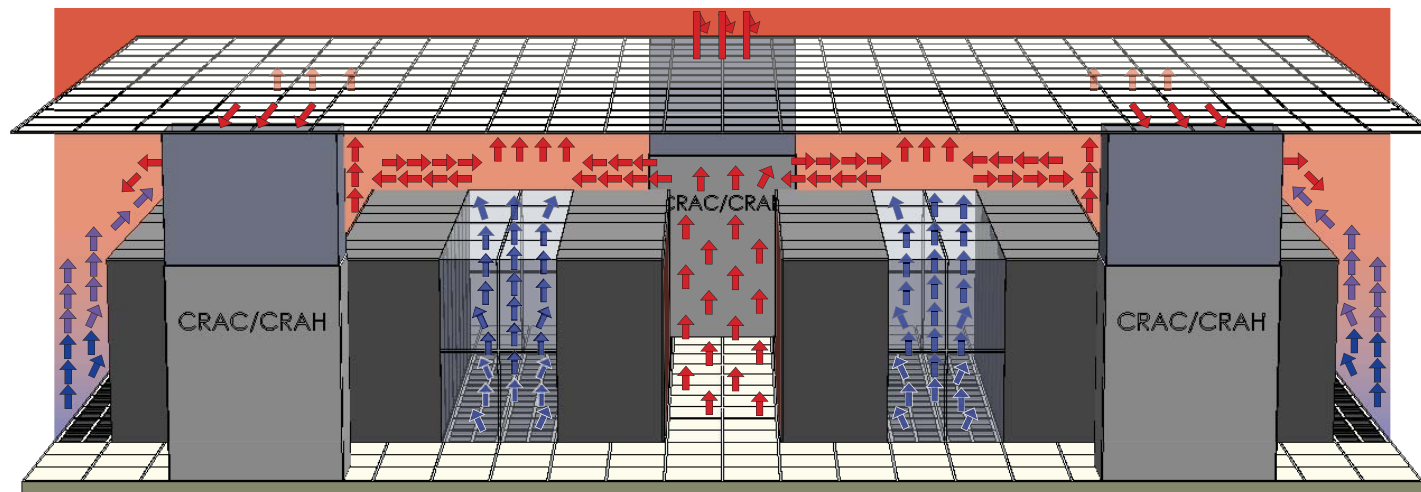

COLD AISLE containment

- + Quick and easy way to increase cooling efficiencies
- + Air mixing virtually eliminated, leading to higher CRAC/CRAH return temperatures
- Underfloor air pressure balance is critical to achieve balanced cooling in all aisles
- Oversupply of air to maintain under floor pressures leads to wasted fan energy
- Not suitable for slab environments
- Majority of white space is “hot aisle” leading to undesirable working conditions
- Doors and ceiling of containment can lead to challenges in lighting and fire suppression

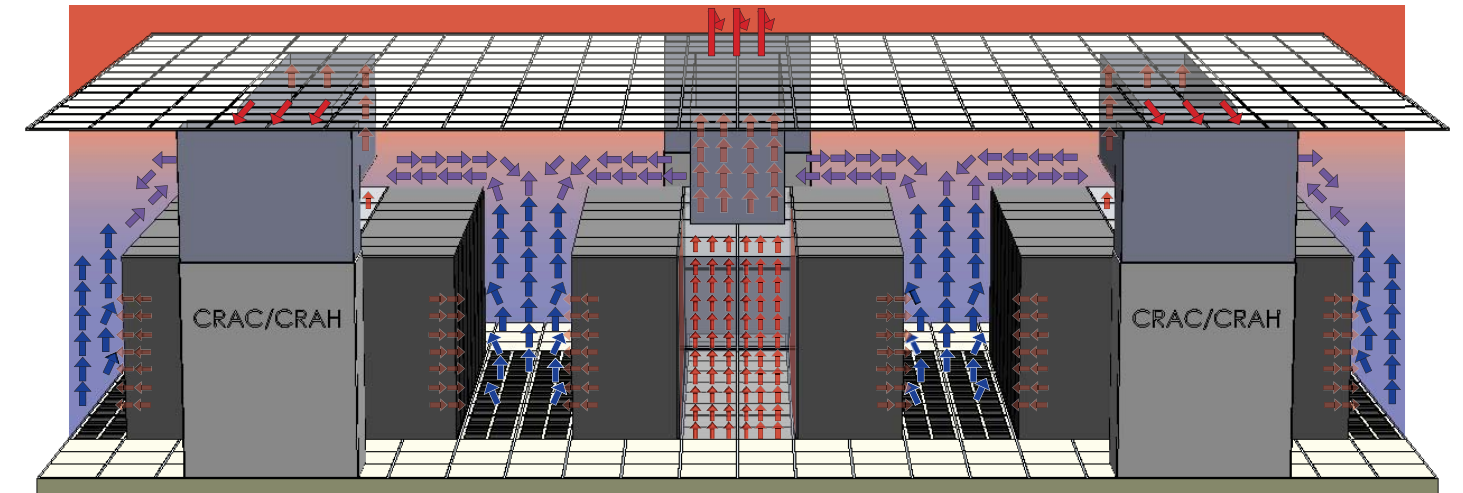

HOT AISLE containment

- + Majority of white space is now cold aisle, improving most working conditions
- + Pressure balance is less critical, suitable for slab deployment
- High containment aisle pressures lead to wrap around heating
- High containment aisle pressures force server fans to speed up, increasing fan speed energy and decreasing cooling efficiency
- Doors and ceiling of containment can lead to challenges in lighting and fire suppression

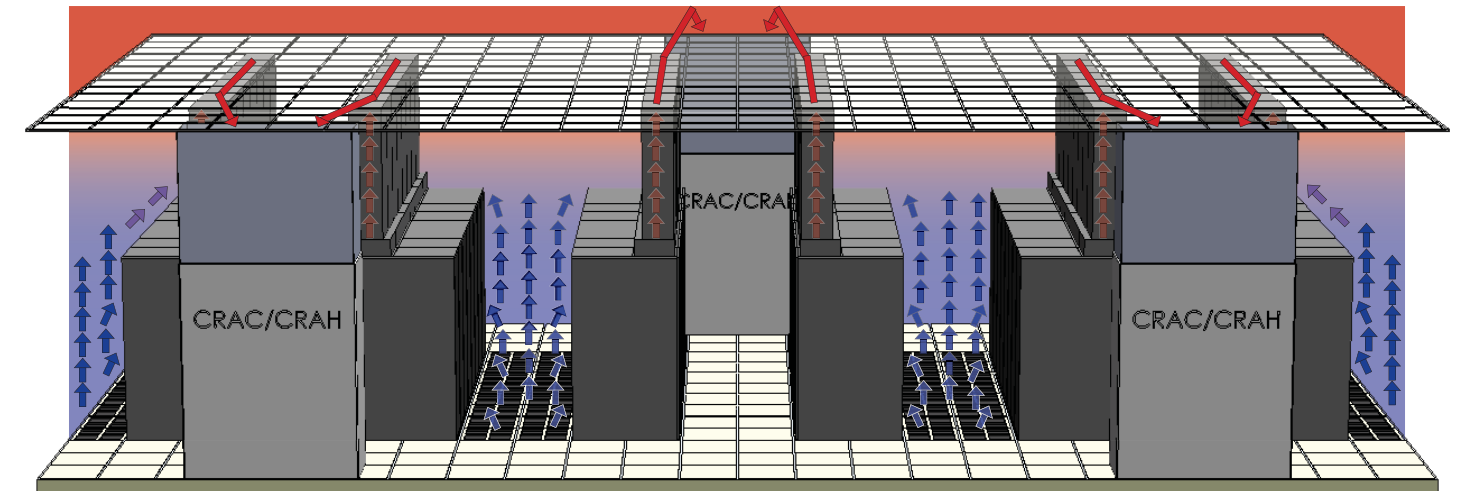

geist's **ACTIVE CABINET** or **ROW BASED** containment method

- + No hot air mixing, no wrap around heating, NO HOT SPOTS
- + Actively balances return airflow to server usage
- + Complete hot air separation enabling highest CRAC/CRAH return air temperatures
- + Eliminates raised floor pressure balancing issues making it suitable for slab environments
- + Data center floor becomes a cold aisle providing comfortable working conditions
- + 1:1 airflow balance makes cooling over-provision unnecessary



Row applications increase operational redundancy; automated feedback cuts total fan energy 40%.

creating a COMMON PLENUM

Using standard components, a common air plenum can be created across multiple cabinets. The common plenum then allows multiple Geist GEC systems to work in concert by utilizing the IP network. This approach allows scalability as required and lowers the total cost of deployment. Plenum components allow placement of Geist GEC systems on variable pitch, with placement options every 6 inches. This allows system placement to avoid overhead obstructions such as cable trays.

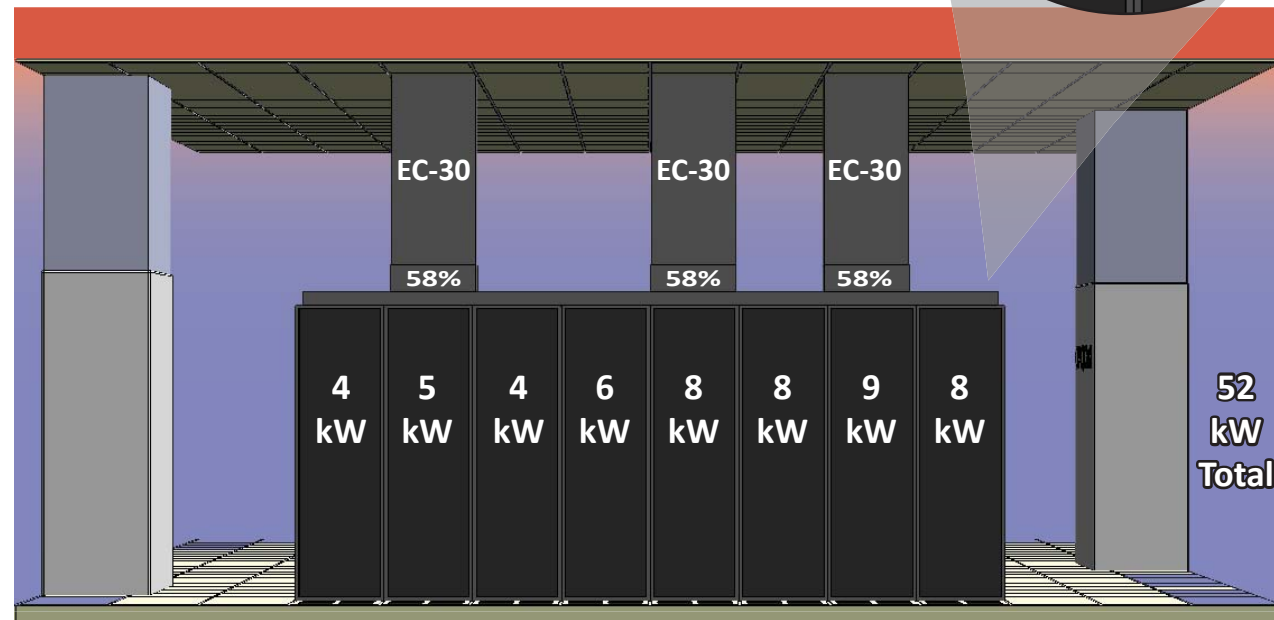
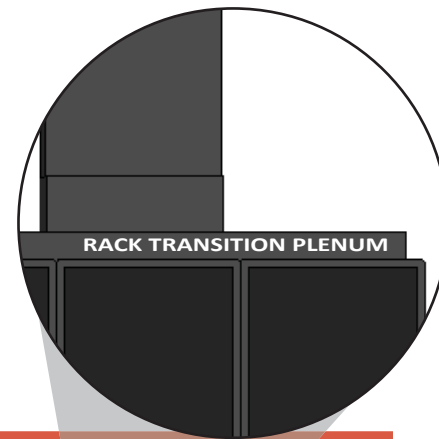

load SHARING

- ✓ Multiple systems work together to share cabinet loads
- ✓ Operational redundancy increased as systems work in concert
- ✓ In the event of utility failure heat continues to be exhausted by the GEC system that is connected to your UPS

SCALABLE capacity

- ✓ System capacity automatically scales as loads are added or removed
- ✓ Automated load sharing returns all heat directly to return air plenum
- ✓ High density loads can be directly coupled for single cabinet isolation
- ✓ Load sharing leads to lower cost per deployed kW

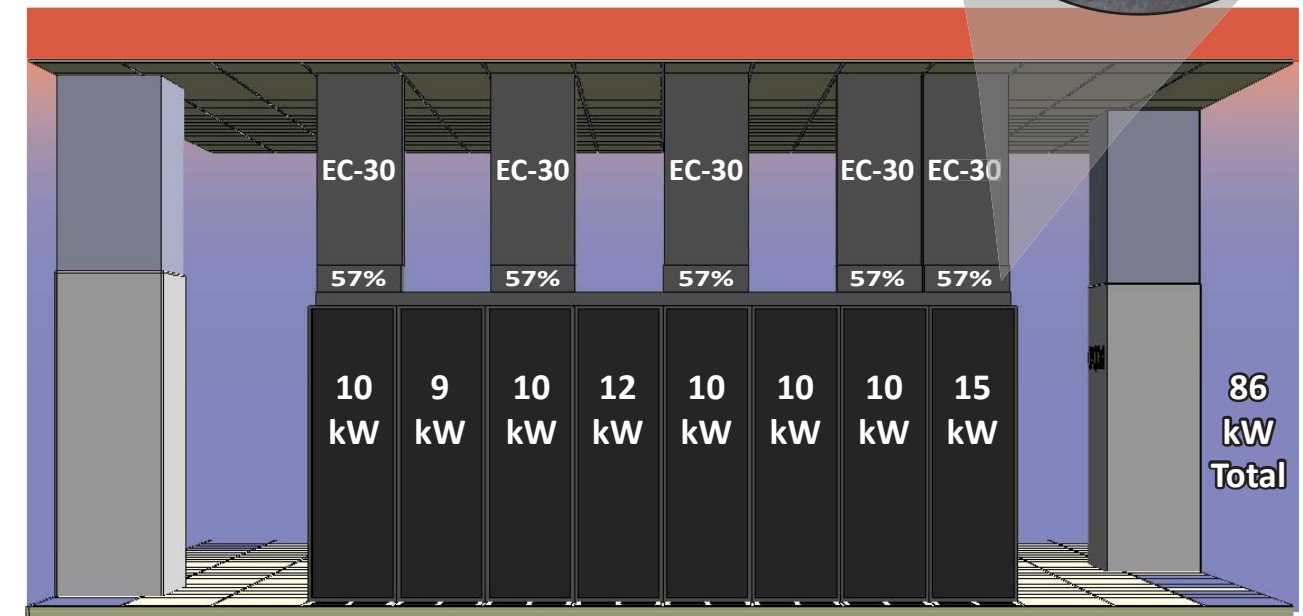

AUTOMATED control

- ✓ Automated load balancing eliminates micromanaging airflow requirements
- ✓ Automatic notification of system threshold breach via e-mail or SNMP
- ✓ Environmental conditions monitored and reported automatically
- ✓ Geist's Environet software aggregates total airflow load and automates defining total airflow requirements, allowing lowered airflow across the data center, saving 40% fan energy





NETWORK SWITCH COOLING

A cost-effective product platform providing superior reliability.

In order to reduce energy consumption by data centers and provide greater flexibility in facility operations, in 2008 ASHRAE increased the acceptable intake temperature for Datacom Equipment to 80.6°F (27°C). While this operational shift has provided significant efficiency gains, it has also increased the number of network operation failures caused by insufficient switch cooling.

Geist's Network Switch Cooling units eliminate these heat related failures by strategically targeting this problem area.

Placing network switch ports facing the rear of rack where server port density resides is convenient and simplifies network cabling. Therefore switches commonly utilize side air intake which is different than the rest of the equipment in the rack. These devices allow cool air from the cabinet front to be delivered to the rear mounted switches. The cooling for the rest of the rack isn't ideal for rear mounted network switches.

the GEIST advantage

- ✓ Maintain a perfectly controlled environment for your network switches
- ✓ Achieve the greatest degree of data center cooling efficiency for network switches and routers with effective cool air delivery for network switches with varying air flow patterns
- ✓ Resolves a critical issue plaguing data centers while reducing operating costs
- ✓ Installs quickly without disrupting network operations
- ✓ Rapid return on investment; typically less than 3 months
- ✓ Stabilizes switch intake temperature within a few degrees of the rack front intake air temperature
- ✓ Continually delivers required cool air
- ✓ Delivers cool air from outside the rack front to rear mounted switches without hot air contamination
- ✓ Enables placing switch inside the rack, even with high-heat loads generated by energy efficient servers

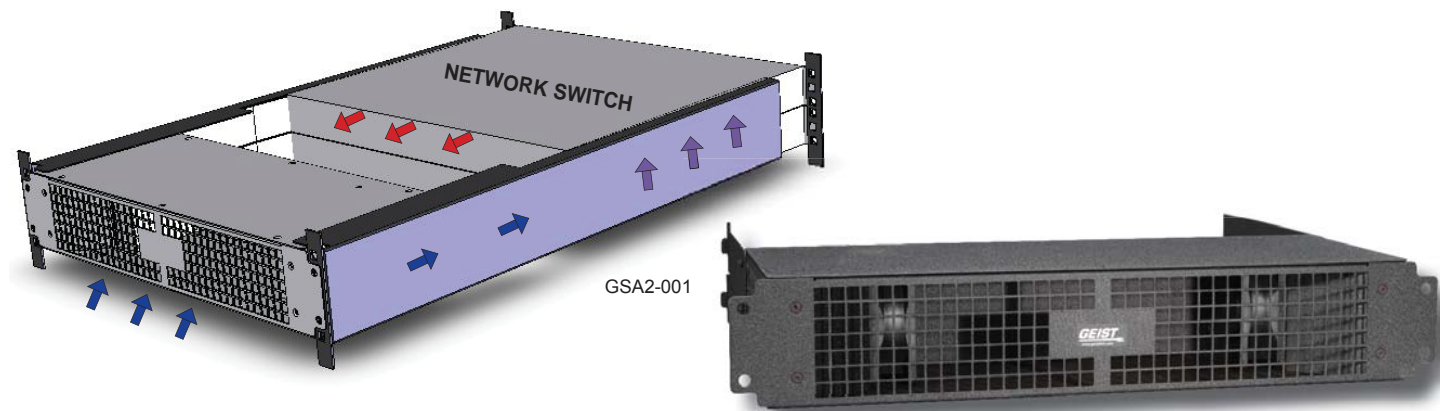

SPECIFICATION

Item Number	GSA1-001	GSA2-001
Configuration	1U	2U
Rear rack mount switch compatibility:	Cisco 4948	Most 1U and 2U, including: Side intake-rear exhaust Side intake-front exhaust Rear intake-front exhaust Combination of above
Air Flow	N/A - passive	48 CFM
Input Power	N/A - passive	90-264 VAC 50/60 Hz / 15 Watts
Input Connector	N/A - passive	C-14 (cord not included)
Conformance	N/A	UL & c-UL 60950, FCC Class A
Mounting Rail Depth Range:	27 5/8" to 29 5/8"	26 5/8" to 29 5/8"
Warranty	Lifetime	2 Year
Installation	1U space between switches required Use blanking panels to block heat	Can be stacked in consecutive U spaces
	<ul style="list-style-type: none"> ✓ Passively delivers cool air to the switch via enclosed channels ✓ Case study evidence documented 15°F (8°C) discharge temperature decreases 	<ul style="list-style-type: none"> ✓ Actively pushes cool air to rear mounted network switches ✓ Works in either 120 or 208V installations ✓ Consumes only 15 watts ✓ Can be stacked and accommodate switches with varying air flow patterns in single installation

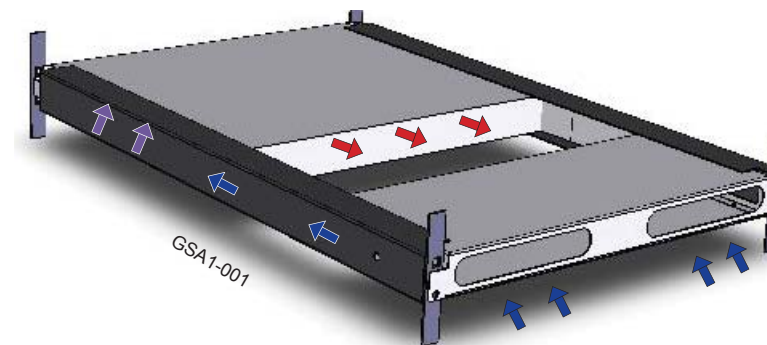



INTELLIGENT COOLING SOLUTIONS

A comprehensive suite of next generation cooling products to provide scalable, cost-effective, high performance solutions.

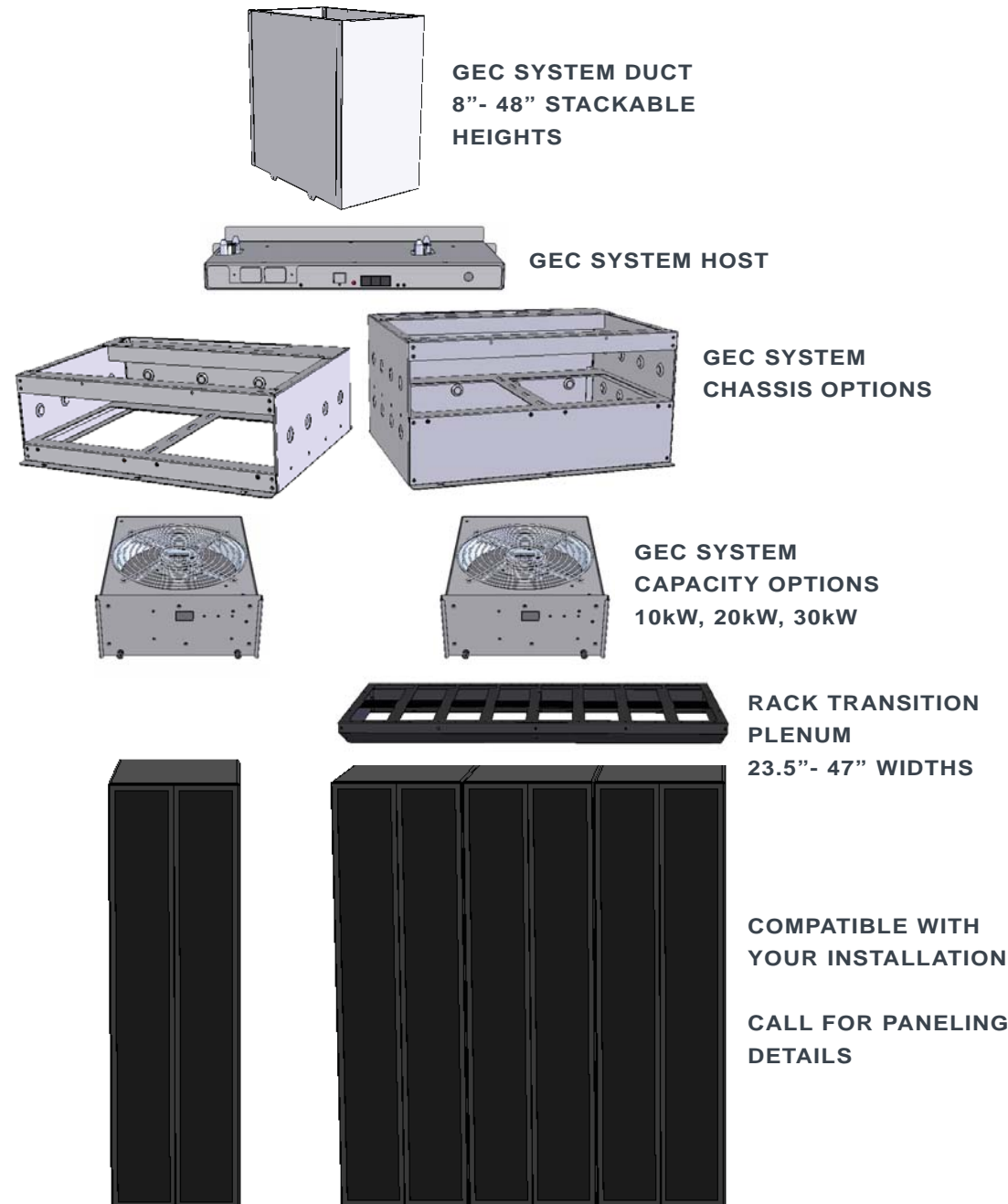

GEC SYSTEMS	GEC1001C	GEC1001CT	GEC1001H	GEC1001H-230V	GEC1001P	GEC10D	GEC20D	GEC30R
GEC10D System	1		1		1	2		
GEC10DT System		1	1		1	2		
GEC10D 230V	1			1	1	2		
GEC10DT 230V		1		1	1	2		
GEC20D System	1		1		1		2	
GEC20DT System		1	1		1		2	
GEC20D 230V	1			1	1		2	
GEC20DT 230V		1		1	1		2	
GEC30R System	1		1		1			2
GEC30RT System		1	1		1			2
GEC30R 230V	1			1	1			2
GEC30RT 230V		1		1	1			2

GEC STRUCTURAL ELEMENTS	
GEC1002-08S	GEC Duct 8" Stackable
GEC1002-10S	GEC Duct 10" Stackable
GEC1002-12S	GEC Duct 12" Stackable
GEC1002-16S	GEC Duct 16" Stackable
GEC1002-24S	GEC Duct 24" Stackable
GEC1002-48S	GEC Duct 48" Stackable
GEC HOST	
GEC1001H	GEC Host 120 - 208V
GEC1001H-SF	GEC Host Single Fan Operation
GEC1001H-230V	GEC Host 230V
GEC CHASSIS	
GEC1001C	GEC Chassis
GEC1001CT	GEC Chassis - Tall
GEC CAPACITY	
GEC10D	GEC 10kW Fan Cartridge
GEC20D	GEC 20kW Fan Cartridge
GEC30R	GEC 20kW Fan Cartridge
GEC ACCESSORIES	
GEC1001P	GEC Pressure Sensor
GEC1001-FB01	GEC Single Fan Blanking Panel
GEC1002-DC1	GEC Inter-Duct Connector 24/600
GEC1002-DC2	GEC Inter-Duct Connector 30/750
GEC1002-DC3	GEC 20" Round Duct Adapter
RTAFHD3	GEC Temperature, humidity, dew point sensor
Satellite Current Monitoring (DM) PDUs	Compatible power strips for this product. A max of 4 can be connected per host.
GEC PLENUM	
GRT600-01	GEC Rack Transition Plenum 23.5"
GRT1200-01	GEC Rack Transition Plenum 47"
GRT750-01	GEC Rack Transition Plenum 750mm
GRT1500-01	GEC Rack Transition Plenum 1500mm



Delivering reliable quality through exceptional products.

When data center managers look to “green” their installation they are typically drawn to cooling, which often times constitutes up to 40% of their energy bill. Cooling infrastructure is expansive and consists of a complex system of chillers, pumps and air handlers. Any changes made to this system must not only reduce energy use, but also maintain optimal operating conditions for the servers. The Variable Speed Fan Controller is located at the critical cross section of a successful “greening” strategy. Real-time temperature measurements can automatically adjust fan speed to protect your equipment, reduce fan noise and conserve energy.



FC-3-2

VARIABLE SPEED fan controller

- ✓ Automated maintenance of optimal cabinet temperature
- ✓ Maintain critical airflow in the event of power failure
- ✓ On-board scrolling display provides local reading of user selected critical data including temperature and fan speed
- ✓ Receive notification of threshold alarm breach via e-mail, SNMP traps and/or XML
- ✓ Interface with IP web cameras for visual monitoring of cabinet or computer room
- ✓ No external software; graphs and logs accessible via any web browser

(RT) temperature SENSOR

Temperature: -40°F to 254°F
 Temperature Accuracy: +/- 1.8°F from 40°F to 122°F
 Precisely monitor “hot spots” throughout your installation.



RT



satellite CURRENT MONITORING (DM) pdu

The Satellite Current Monitoring PDU allows you to minimize the number of IP addresses used while maximizing the number of Current Monitoring PDUs in your installation. The local current meter facilitates moves, adds and changes, while remote access is available for ongoing oversight. Geist Satellite Current Monitoring PDUs are offered in the same wide range of configurations as the popular Current Monitoring PDUs, which feature outlet, breaker, circuit, and aggregate level monitoring and alarming. For a complete list of configurations see www.geistmfg.com.

BLANKING panels

To maintain proper airflow and prevent air recirculation, Geist offers a variety of cabinet blanking panels. A rack without blanking panels can result in thermal damage due to improper cooling as well as excessive energy consumption and an increased carbon footprint. Each Geist blanking panel is engineered with an overlapping lip (see diagram A) for an improved seal to deliver lower temperature air to the hottest area, the upper third of the cabinet.

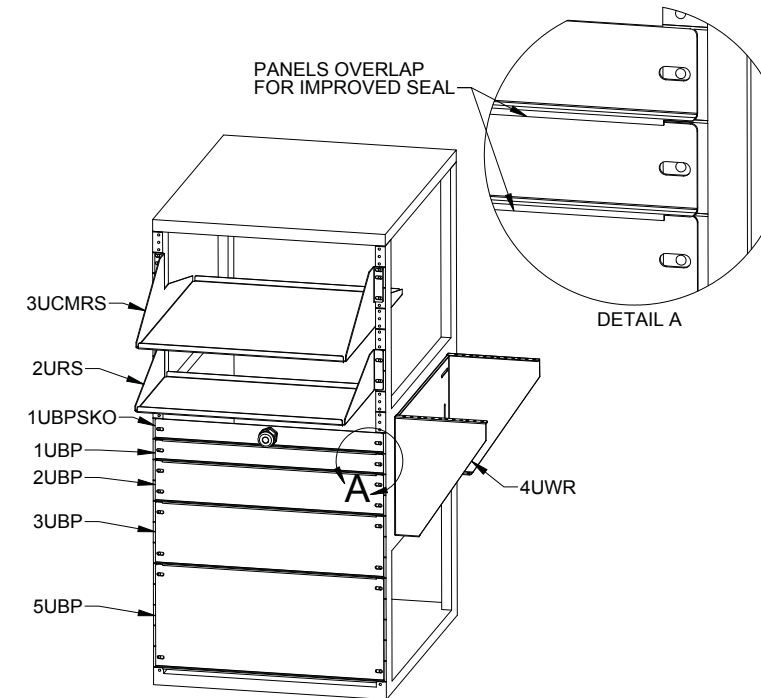

Part #	Description
1UBP	1U Blanking panel
1UBPSKO	1U Blanking panel with sensor knock out
2UBP	2U Blanking panel
3UBP	3U Blanking panel
5UBP	5U Blanking panel

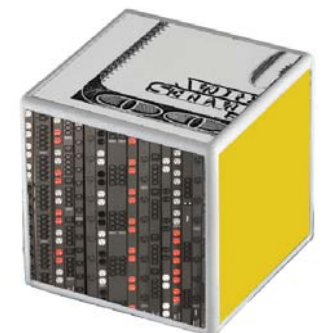

Choosing the software solution that protects your investment is critical, Geist software provides this plus so much more...

Geist GEC Cooling Systems enable self-containment of airflow and cooling in a data center environment. Designed for highly efficient, cooling service delivery across each cabinet or row the system operation is based on the current IT load demand. With this type of design the Geist Cooling solution continues to expand the capacity and performance of existing data center airflow distribution systems.

Geist Balanced Airflow Module aggregates cabinet airflow data in a single point, enabling supply side control of airflow to match total IT load requirements. Reducing CRAC/CRAH fan speeds based on total airflow requirements can reduce total data center fan energy by up to 40%, offering significant operating expense savings.

With heat fully contained and airflow matched to IT load, supply temperatures can be raised to enable further saving in cooling. Increased supply temperatures can account for significant increases in free cooling days without the use of direct expansion (DX) cooling.

Balanced Airflow Module can be supplied as a stand alone module, or incorporated into a Geist Environet system for end to end data center infrastructure management (DCIM).



ENVIRONET facilities management system

Environet is a highly customizable, fully scalable system with a single point of access for all your monitoring needs. Environet provides monitoring, trending, alarming, and custom views of up to tens of thousands of monitored data points. The aggregated results are collected across your facilities and presented through a visually rich graphical user interface.

- Custom views of all data: shows the most pertinent information based on your monitoring needs for faster, more efficient data collection.
- Extensive trend and historical records: no more manual measurements! Saves time by automatically collecting and logging important data points.
- Full alarm management: gives you the flexibility to manage alarms remotely so no alarm goes unacknowledged.
- Industry leading monitoring and management features: monitor your facility proactively rather than reactively. The extensive tool set allows you to recognize problem areas before they cause downtime.
- Automated reports: automatically generates required reports saving you time, while decreasing human error associated with running reports.
- Integration with all major BMS and NMS: easily works with current systems so there is no need to replace expensive equipment already installed.
- Multi-site capable: gives you a holistic view of your enterprise for maximum enterprise efficiency.
- Multi-user based views and permissions: increases efficiency by personalizing what information is displayed when you log in.
- Scalable from 10's of points to 10's of thousands of points: allows Environet to grow with your facility. Additional data points are easily added when you need to expand.
- Vendor / MFG neutral: works with existing equipment so you get reliable, efficient monitoring results.
- Control enabled: increases facility efficiency allowing you to realize your return on investment more fully.



Equipment View



Facility View

